

BODY PARTS LIST OF B08(TWIN LIGHT 50cc)

VENTO RX8 B08
DUAL LIGHT



**STEERING**

NO.	CODE		QTY.
1	40100B920001	HANDLE COMP.	1
2	B01591004565	BOLT 10×1.25×45MM	1
3	B04171012555	U NUT 10×1.25MM	1
4	40001T090001	L. GRIP	1
5	40210T090001	R. GRIP ASSY.	1
6	40211T090001	R. GRIP	1
7	40212T090001	THROTTLE GUIDE TUBE	1
8	40300B910001	CABLE ASSY. THROTTLE	1
9	40008B910000	JACKET,RR. BRAKE CABLE	1
10	B02000501025	SCREW 5×10MM	1
11	40270B920000	BRAKE CABLE ASSY.	1
12	40273B910000	PIN,STOP(GOLD COLORED)	1
13	40271B910000	NUT, ADJUSTING	1
14	40340B910001	JUNCTION BOX	1
15	40274B920000	SPRING (GOLD COLORED)	1
16	40306B910000	CABLE THROTTLE 1	1
17	40307B910000	CARBURETOR LINE	1
18	40308B910000	OIL PUMP LINE	1

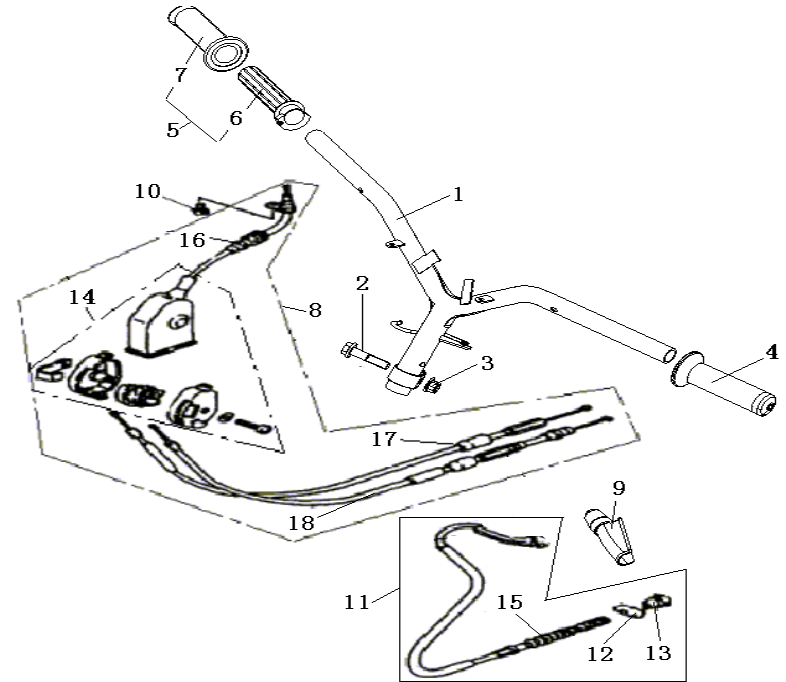

LEVER/HANDLE SWITCH

NO.	CODE		QTY.
1	40500B910000	LEFT HANDLE SWITCH ASSY.	1
2	40002B910000	LEFT LEVER	1
3	40004B310000	LEVER MOUNTING SCREW	1
4	B04000500065	NUT 5MM	1
5	91700B310000	STOP SWITCH ASSY.	1
6	40600B91000A	RIGHT HANDLE SWITCH ASSY.	1
7	40610B91000A	RIGHT HANDLE SWITCH	1
8	40620B910000	R. SWITCH FIXING SEAT	1
9	B02000502025	PAN HEAD SCREW 5×20MM	2
10	B02000502525	PAN HEAD SCREW 5×25MM	2
11	40510B910000	LEFT HANDLE SWITCH	1
12	40520B910000	L. SWITCH FIXING SEAT	1
13	B07000000505	SPRING WASHER 5MM	1

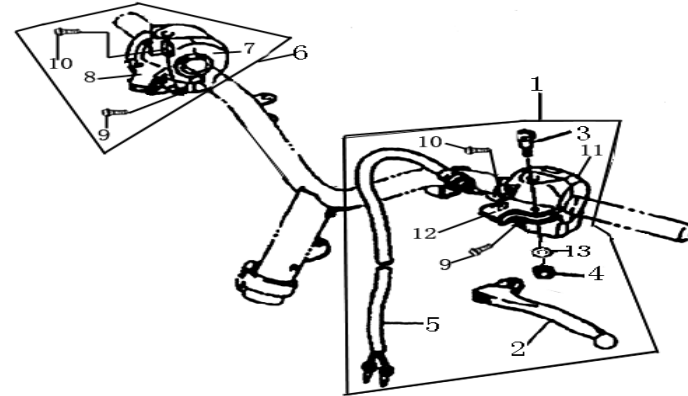

FRONT FORK ASSY.

NO.	CODE		QTY.
1	43300B920001	FR.R. FORK ASSY.	1
2	43200B920001	FR. L. FORK ASSY.	1
3	43100B920003	STEM, STEERING	1
4	43008B310000	NUT	2
5	43005B920001	BALL RACE COVER	1
6	43001B920002	BALL RACE, CONNECTING	1
7	B06010150000	STEEL BALLφ5 (A SET OF	42
8	43003B920000	BALL RACE	2
9	43004B920000	BALL RACE	1
10	43204B920001	CAP BOLT	2
11	43150B310000	CLIP, SPEEDOMETER CABLE	1
12	43290K010000	DUST SEAL	2
13	43207K010000	CLIP	2
14	43260K010000	OIL SEAL	2
15	B01090601265	BOLT 6X12MM	1
16	43035B920000	HOLDER, BRAKE HOSE 2	1
17	43000B920001	FRONT FORK ASSY.	1
18	43021B910003	HOLDER, BRAKE HOSE 1	1
19	B01591003065	BOLT 10X1.25X30MM	2
20	B01070601665	BOLT 6X16MM	2

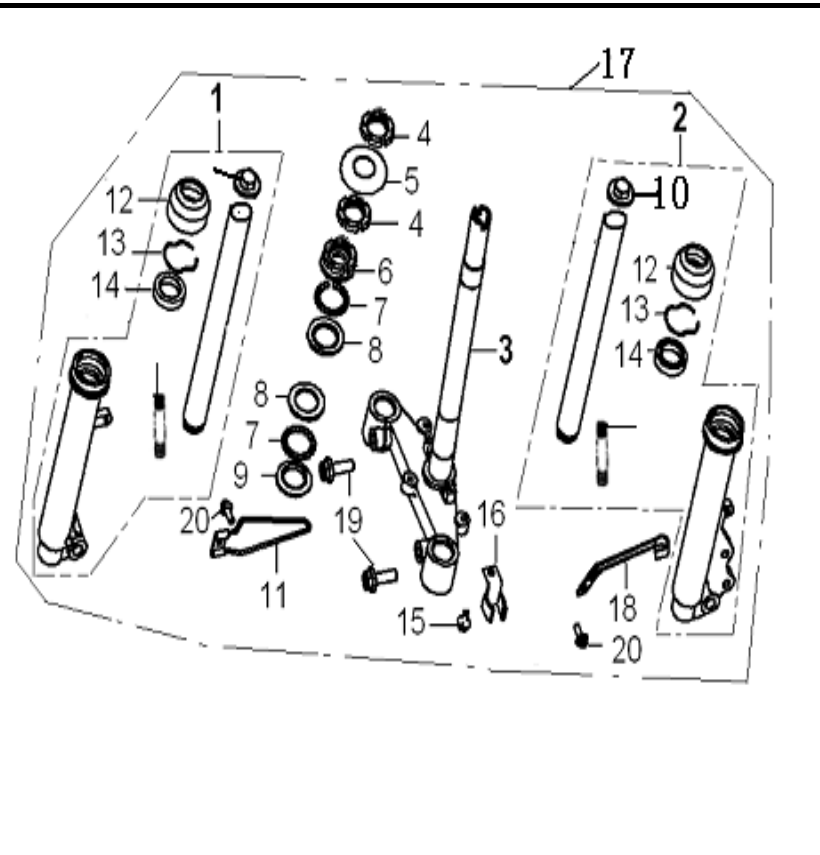

FRONT WHEEL ASSY.

NO.	CODE		QTY.
1	44100B91RH02	FR. RIM COMP. 3.5×12" (RED)	1
1	44100B91YE02	FR. RIM COMP. 3.5×12" (YELLOW)	1
1	44100B91LK02	FR. RIM COMP. 3.5×12" (BLUE)	1
2	44600B910910	DISTANCE COLLAR COMP.	1
3	44300B910000	OIL SEAL 22×35×7	1
4	B12016020100	BALL BEARING 6201-2RS	2
5	B140707D1211	TIRE 120/70-12 (ZHONGYIN DOT)	1
6	B1403Z201100	RIM VALVE Z2-01-1	1
7	B04171212563	U NUT 12×1.25MM	1
8	44004G250000	FR.WHEEL AXLE	1
9	44005B910000	COLLAR	1
10	44200B91BH00	SPEEDOMETER GEAR COMP BLUE	1
11	B1404Z2011C0	CAP, VALVE	1

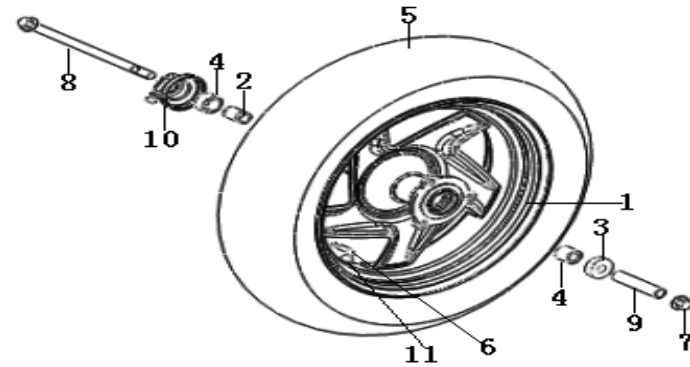

FRONT DISK BRAKE

NO.	CODE		QTY.
1	45000T10B303	DISC BRAKE ASSY., FR.(UP AND DOWN, BLACK)	1
2	45014B920000	LEVER (145MM (φ14MM))	1
3	45015T400000	LEVER MOUNTING SCREW	1
4	B04160600065	NUT 6MM	1
5	45400B92B300	MASTER CYLINDER COMP. (BLACK)	1
6	45023T010000	MASTER CYLINDER BRACKET	1
7	B01070602365	BOLT 6×23MM	1
8	45200B920000	FR. BRAKE HOSE	1
9	45500T100B30	CALIPER ASSY. (BLACK)	1
10	45110T100000	BRAKE PAD KIT ASSY	1set
11	45300T030000	STOP SWITCH ASSY.	1
12	45033B92C100	BRAKE DISC(SILVER)	1
13	45036B310000	BOLT	3
14	45653B920000	WASHER	2
15	45651B920000	FLANGE BOLT	1
16	45039T100001	BOLT 8×36MM	2

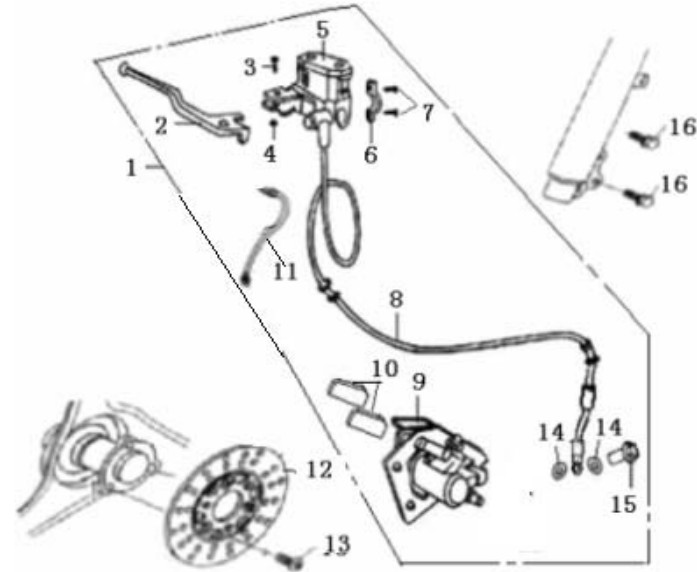

MUFFLER

NO.	CODE		QTY.
1	48300B910000	MUFFLER ASSY.	1
2	B01070601665	BOLT 6X16MM	1
3	47100B91000G	MUFFLER ASSY.COMP	1
4	47490B910000	CUSHION	1
5	47200B030006	MUFFLER ASSY.	1
6	B01090802065	BOLT 8X20MM	2
7	B01090601665	BOLT 6X16MM	2
8	47800B070000	GASKET, EXHAUST PIPE	1
9	47833B140005	ADIABATIC RUBBER	1
10	48831B140005	MUFFLER HOOP	1
11	47006J010000	NUT 6MM	3

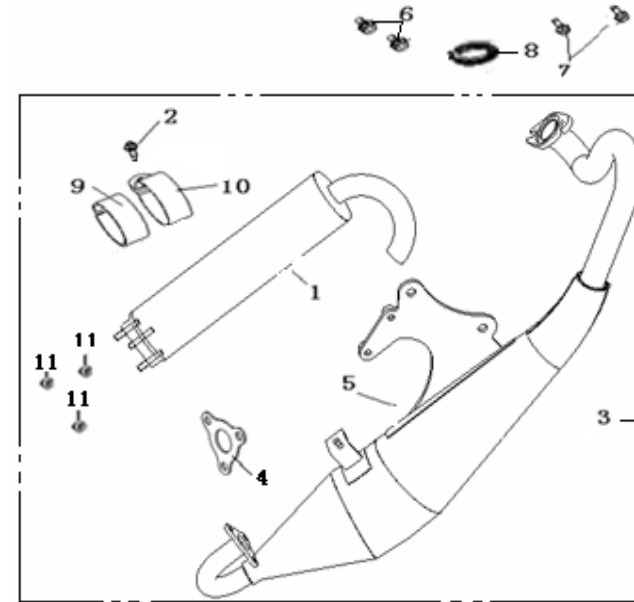

AIR CLEANER

NO.	CODE		QTY.
1	49200B920000	FILTER	1
2	B05074202005	TAPPING SCREW 4.2×20MM	5
3	B01090602065	BOLT 6×20MM	2
4	49016B910000	CLIP 42.5	1
5	49000B920001	AIR CLEANER ASSY.	1
6	49371B070000	GUIDE, BRAKE CABLE	1
7	B05074201205	TAPPING SCREW 4.2×12MM	4
8	B01090601265	BOLT 6×12MM	2
9	57051B140000	PLATE, ONE WAY VALVE	1
10	49853B920002	HOSE II 200MM	1
11	49852B920001	HOSE I 250MM	1
12	49851B920002	HOSE 260MM	1
13	49840W110000	ONE WAY VALVE II	1
14	49805B920000	SPRING II, LOCK ϕ 17.5	4
15	49870B140000	AIR CLEANER, SMALL	1
16	49855W110000	SPRING II, LOCK ϕ 16.5	2

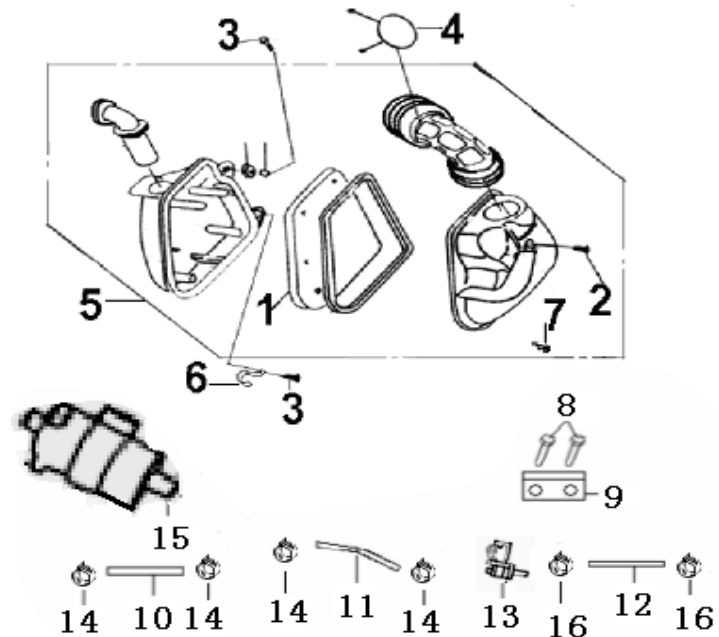

FUEL TANK

NO.	CODE		QTY.
1	50100B920002	FUEL TANK COMP.	1
2	B01090601665	BOLT 6×16MM	4
3	50300B910000	FUEL COCK ASSY.	1
4	50301B910000	FUEL HOSE 1 , φ4.5×φ8.5×80	1
5	50316B920000	SPRING(BLACK)	1
6	50307B910000	CLIPφ8	4
7	50302B910000	VACUUM HOSE,φ4×φ8×360	1
8	50306B910000	CLIPφ7	2
9	50303B910000	FUEL HOSE 2,	1
9	50303B910000	φ4.5×φ8.5×250	1
10	50340T020000	FUEL FILTER ASSY.	1
11	50800B920000	SENDER UNIT	1
12	50801B910000	BOLT 5×16MM	4
13	50004B920000	SENDER UNIT GASKET	1
14	50312T020000	SEAL RING	1
15	B07020000505	WASHER 5MM	4
16	50352B910000	FUEL FILTER	1

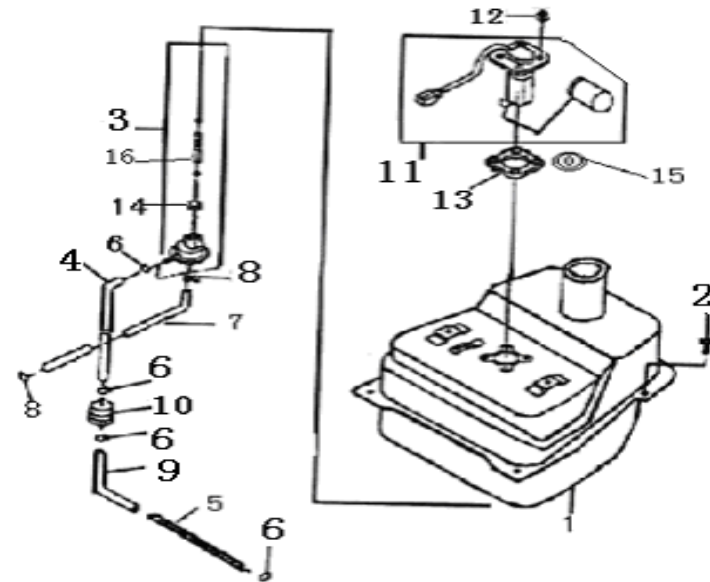

SEAT

NO.	CODE		QTY.
1	51100B92001K	SEAT ASSY.RED/BLACK	1
1	51100B92002K	SEAT ASSY.YELLOW/BLACK	1
1	51100B92003K	SEAT ASSY.BLUE/BLACK	1
2	51080B920001	SEAT HINGE	1
3	08032B910000	O-RING 84.4×3.1	1
4	08011H010000	BOLT 6×14MM	2
5	51004B920001	LUGGAGE BOX	1
6	B07030000805	WASHER 8MM	2
7	08017T090000	BOLT W/WASHER 6×20MM	2
8	52011B33BA00	RR.. CARRIER COMP (BLACK)	1
9	B02050804565	SCREW 8×45MM	4
10	08027T090000	WASHER	2
11	05536B920001	NOISE .CONTROL , 1 (DOT)	1
12	05535B920000	WARNING STICKER (DOT)	1
13	05533B920001	TIRE PRESSURE (DOT)	1
14	05536B920002	NOISE .CONTROL , 2 (DOT)	1

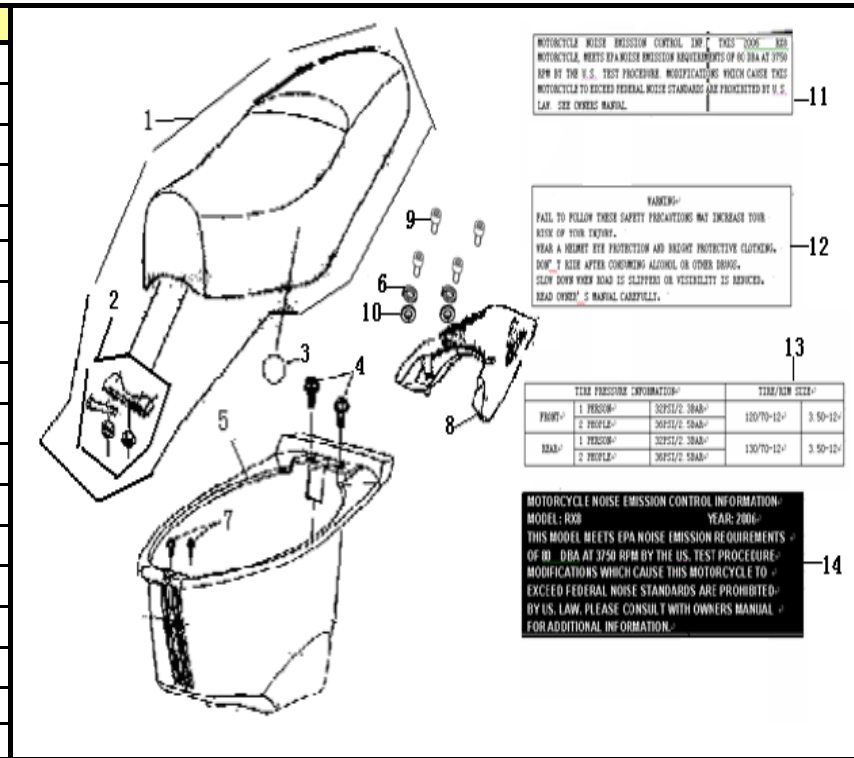

REAR WHEEL

NO.	CODE		QTY.
1	54100B91RH02	RR .RIMCOMP.3.5×12" (RED)	1
1	54100B91YE02	RR .RIMCOMP.3.5×12" (YELLOW)	1
1	54100B91LK02	RR .RIMCOMP.3.5×12" (BLUE)	1
2	B140708D1211	TIRE 130/70-12 (ZHENGYIN DOT)	1
3	B1403Z201100	RIM VALVE Z2-01-1	1
4	54200B920000	BRAKE SHOE KIT	2
5	54001B920000	SPRING BRAKE SHOE	2
6	54003B910000	CAM SHAFT	1
7	54007B910000	CAM SHAFT LEVER	1
8	54002B910000	INDICATOR PLATE	1
9	54008B920000	TENSION SPRING	1
10	08012B910000	HEX. BOLT M6X30	1
11	B04171601553	U NUT 16X1.5MM	1
12	B1404Z2011C0	CAP, VALVE	1
13	65701B920001	REAR FENDER	1
14	B01090602065	BOLT 6X20MM	2
15	65803T020000	SPRING NUT M6	2
16	B190101000A0	O RING 10×1.9MM	1

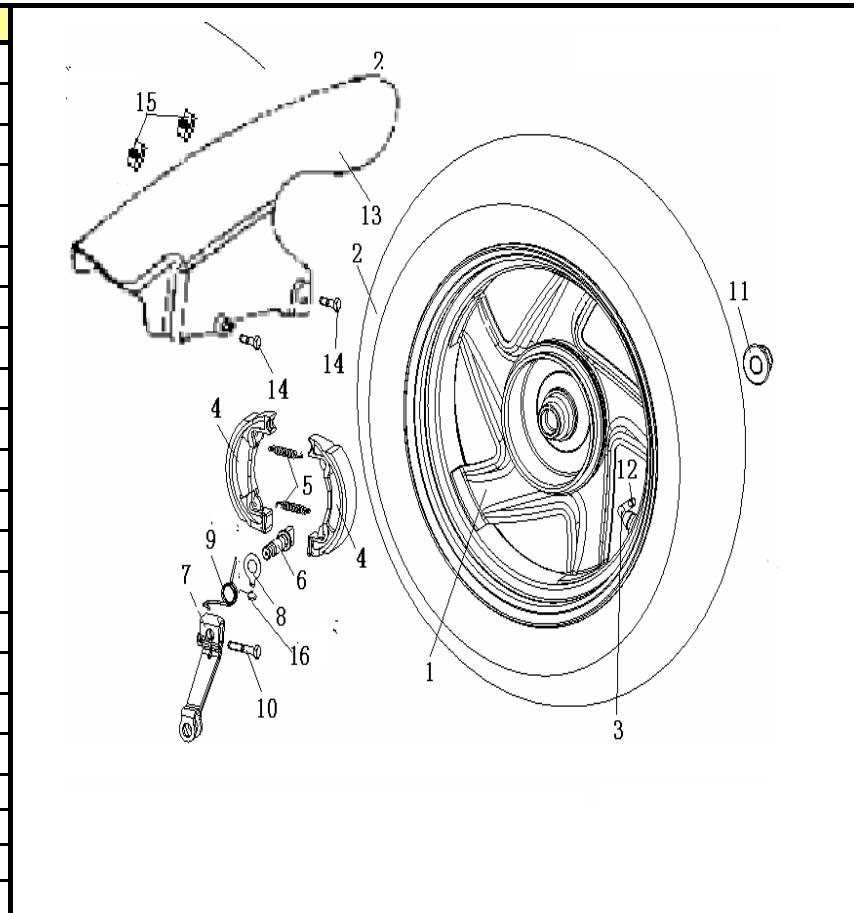

FRAME BODY

NO.	CODE		QTY.
1	57100B920007	FRAME COMP.	1
2	58303B910001	E/G MOUNTING BOLT M12X1.25Y280	1
3	B04171212565	U NUT 12X1.25MM	1
4	58301B920000	E/G MOUNTING BOLT,	2
5	B04171012555	U NUT 10X1.25MM	2
6	58360B920000	E/G BRKT COMP.	1
7	58302B070000	DAMPER	2
8	58304B920000	SPRING	2
9	58800B910000	SEAT CATCH COMP.	1
10	B01090602565	BOLT 6X25MM	2
11	57080B330000	CARRIER BRACKET	1
12	B01090601265	BOLT 6X12MM	5
13	58350B310000	BUFFER, ENGINE BRACKET	2
14	58900B920000	SEAT CABLE	1

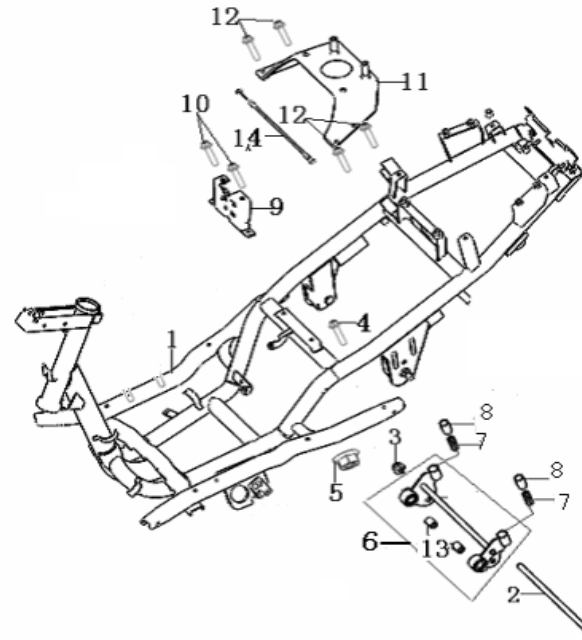

REAR ABSORBER

NO.	CODE		QTY.
1	63100B91RH00	RR. ABSORBER COMP. (RED)	1
1	63100B91YE00	RR. ABSORBER COMP. (YELLOW)	1
1	63100B91LK00	RR. ABSORBER COMP. (BLUE)	1
2	63015T020000	FLANGE BOLT , 8X31MM	1
3	B01141004063	BOLT.W/HOLE 10X1.25X40MM	1
4	63016B070000	SPLIT PIN	1

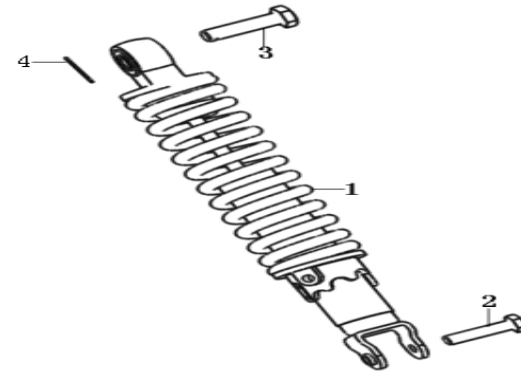

FRONT FENDER

NO.	CODE		QTY.
1	65101B92RH00	FRONT FENDER, (PLATINA CL)	1
1	65101B92YE00	FRONT FENDER, (RED R8)	1
1	65101B92LK00	FRONT FENDER, (BLUE EH)	1
2	B04000500063	NUT 5MM	2
3	66300B920000	REFLECTOR (AMBER DOT)	2
4	65130B920000	FRONT FENDER BRACKET, 1	1
5	65140B920000	FRONT FENDER BRACKET, 2	1
6	65114B920000	SCREW W/WASHER M6X16	4
7	B07030000503	WASHER 5MM	2

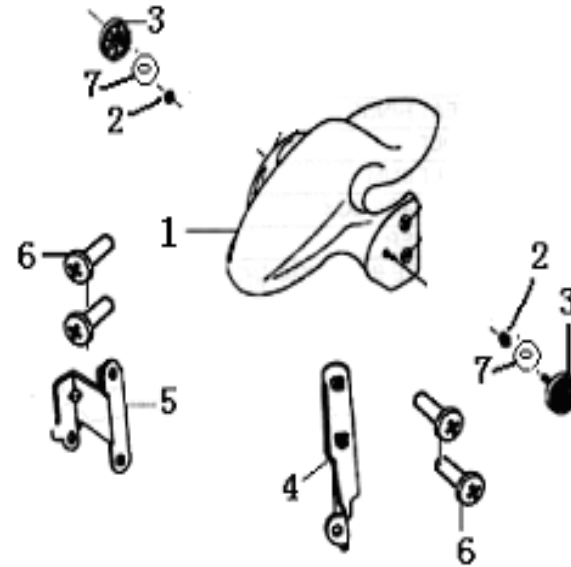

HANDLE COVER

NO.	CODE		QTY.
1	65201B92RH02	HANDLE COVER, 1, (RED)	1
1	65201B92YE02	HANDLE COVER, 1, (YELLOW)	1
1	65201B92LK02	HANDLE COVER, 1, (BLUE)	1
2	65202B920000	HANDLE COVER, 2	1
3	65203B920000	METER VISION ASSY.	1
4	B05075001605	TAPPING SCREW 5×16MM	2
5	B05075001205	TAPPING SCREW 5×12MM	2
6	B05074001205	TAPPING SCREW 4×12MM	2
7	B05074001605	TAPPING SCREW 4×16MM	2
8	B05073001005	TAPPING SCREW 3×10MM	4
9	B13010501405	SCREW 5×14MM	1
10	40480B92RH00	REAR VIEW MIRROR ASSY., R(E) MARK, (RED)	1
10	40480B92YE00	REAR VIEW MIRROR ASSY., R(E) MARK, (YELLOW)	1
10	40480B92LK00	REAR VIEW MIRROR ASSY., R(E) MARK, (BLUE)	1
11	40450B92RH00	REAR VIEW MIRROR ASSY., L(E) MARK, (RED)	1
11	40450B92YE00	REAR VIEW MIRROR ASSY., L(E) MARK, (YELLOW)	1
11	40450B92LK00	REAR VIEW MIRROR ASSY., L(E) MARK, (BLUE)	1

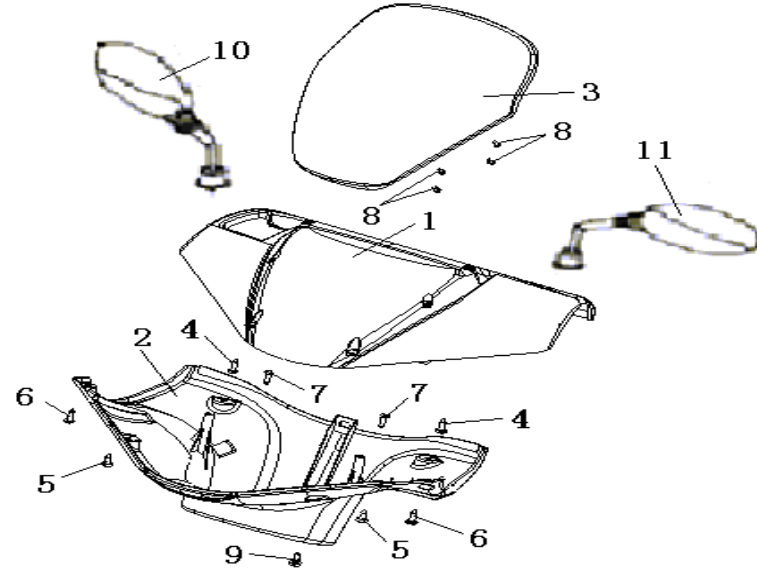

FRONT COVER

NO.	CODE		QTY.
1	65301B92013A	LEG SHIELD, (RED/BLACK)	1
1	65301B92024A	LEG SHIELD, (YELLOW/BLACK)	1
1	65301B92014A	LEG SHIELD, (BLUE/BLACK)	1
2	65314B920000	SCREW	1
3	08027T090000	PLASTIC WASHER	1
4	B05074201605		4
5	65367B920000	COVER , R	1
6	65366B920000	COVER , L	1
7	B05074001205	TAPPING SCREW 4×12MM	6
8	65801B310000	SPRING NUT 4MM	4

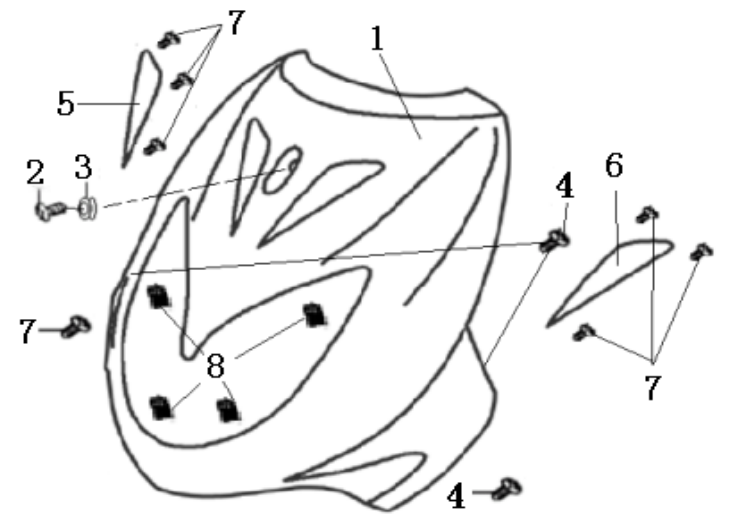

LEG SHIELD

NO.	CODE		QTY.
1	65402B920000	LEG SHIELD, 2	1
2	65406B920020	UNDER COVER(SILVER/BLACK)	1
4	B05074801605	TAPPING SCREW 4.8X16MM	8
5	65407B3330000	INNER FENDER	1
6	B01090603065	BOLT 6X30MM	1
7	65403B920000	INSPECT COVER	1
8	51011B920000	HOOK, HELMET	1
9	B05074201605	TAPPING SCREW 4.2X16MM	8

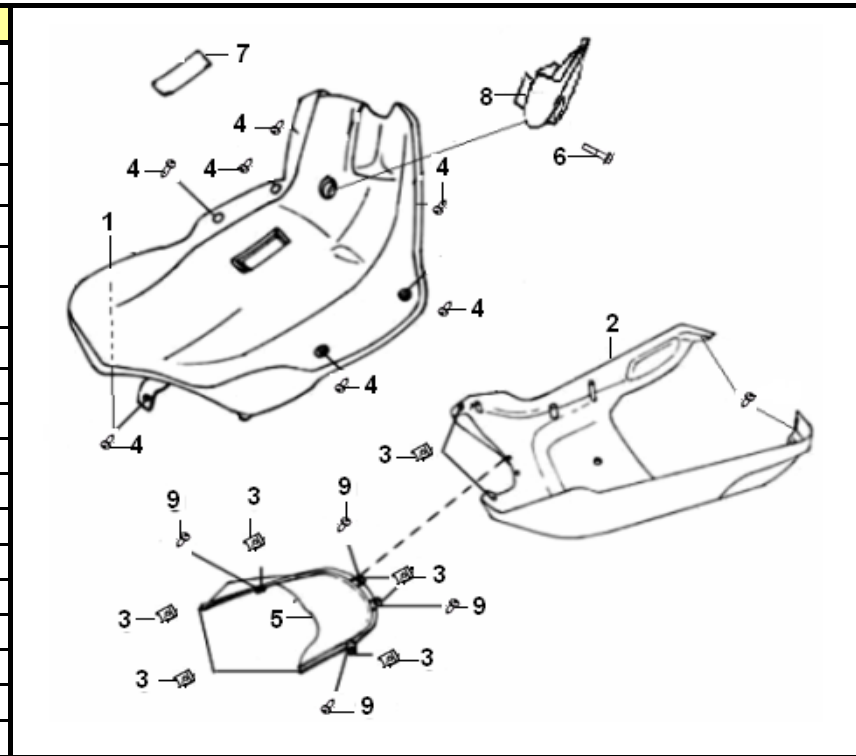

FOOTREST/STAND

NO.	CODE		QTY.
1	58520B910002	MAIN STAND COMP.	1
2	58590B910000	PIN	1
3	B190101000A0	O-RING 10X1.8	1
4	58508B070000	PLATE WASHER	1
5	63016B070000	SPLIT PIN	1
6	58510B910000	MAIN STAND SPRING ASSY.	1
7	58507B910000	CUSHION, MAIN STAND	1
8	B04020800053	NUT 8MM	1
9	08011B290000	BOLT, SINGLE STAND	1
10	57031B920000	WASHER	8
11	57003B910000	SIDE STAND SPRING	1
12	58700B910000	SIDE STAND COMP.	1
13	B07030000505	WASHER 5MM	4
14	B05074001605	TAPPING SCREW 4X16MM	6
15	08011H010000	BOLT 6X14MM	4
16	B01090601265	BOLT 6X12MM	4
17	65802B310000	SPRING NUT 4.8MM	6
18	B05075001605	TAPPING SCREW 5X16MM	1
19	65401B920000	FLOOR, BLACK	1

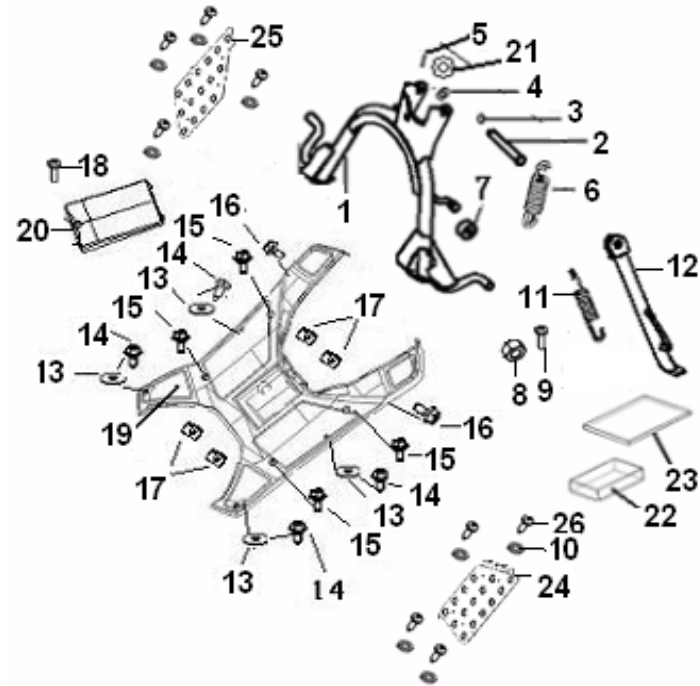

FOOTREST/STAND

NO.	CODE		QTY.
20	65813B920000	BATTERY COVER	1
21	B07030001005	WASHER 10MM	1
22	65812B920000	BATTERY DAMPER II	1
23	65811B920000	BATTERY DAMPER I	1
24	65411B920000	FOOT PLATE , L	1
25	65412B920000	FOOT PLATE , R	1
26	B05004201305	SCREW 4.2X13MM	8

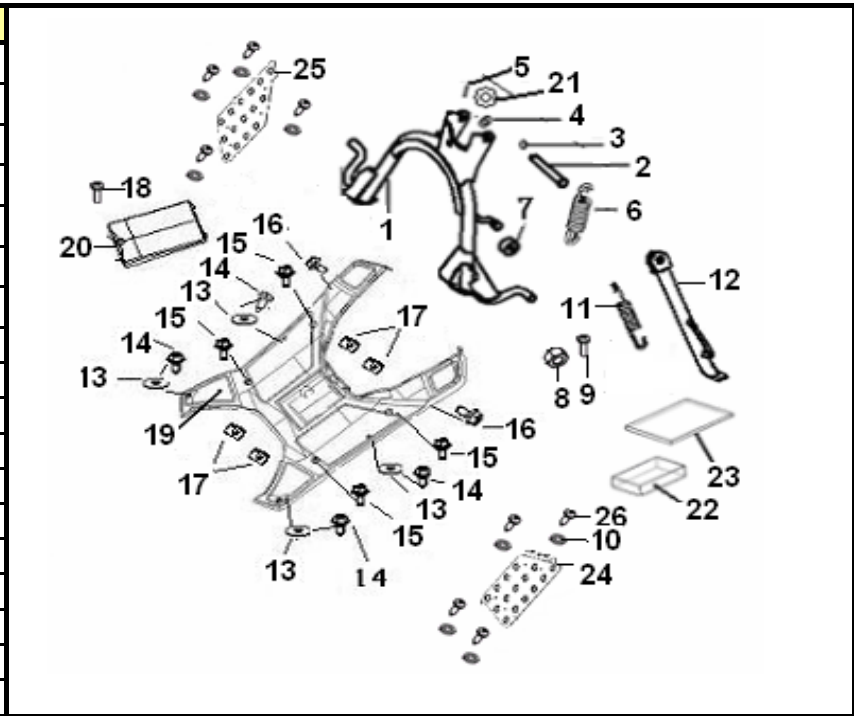

SIDE COVER

NO.	CODE		QTY.
1	65601B92BA00	SIDE COVER,1 (BLACK)	1
2	65602B92BA00	SIDE COVER, 2 (BLACK)	1
3	65605B920001	SIDE COVER, 3	1
4	65619B920000	SIDE COVER, 4	1
5	65606B92BA00	SIDE COVER, 5, (BLACK)	1
6	B05074001205	SCREW 4×12MM	4
7	B05075001605	SCREW 5×16MM	5
8	65802B310000	SPRING NUT 5MM	4
9	B05075001205	SCREW 5×12MM	4
10	65608B920000	CAP , DECORATION	2
11	B02000602023	SCREW 6×20MM	2
12	08021B920000	WASHER	2
13	65616J000000	RUBBER WASHER	2
14	65627B920000	BUSH	2
15	66300B920001	REFLECTOR (RED DOT)	2
16	B04070600053	NUT 6MM	2

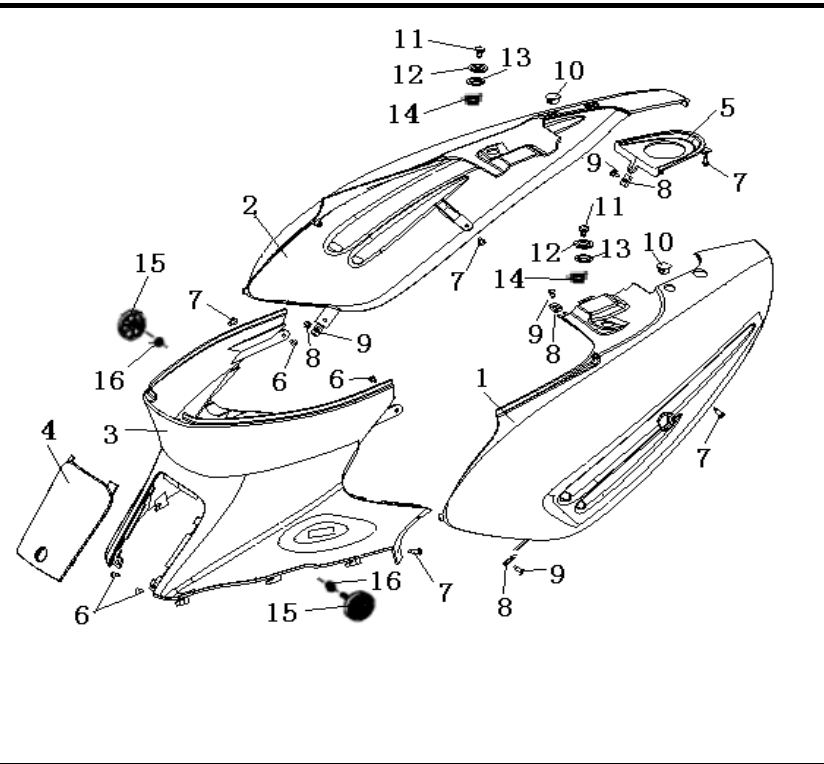

OIL TANK.

NO.	CODE		QTY.
1	64001B310000	OIL TANK	1
2	64090B310000	OIL TANK CAP	1
3	B01090601665	BOLT 6×16MM	2
4	64100B310000	OIL LEVER GAUGE ASSY.	1
5	50307B910000	CLIP φ8	1
6	64000B310000	OIL TANK ASSY.	1

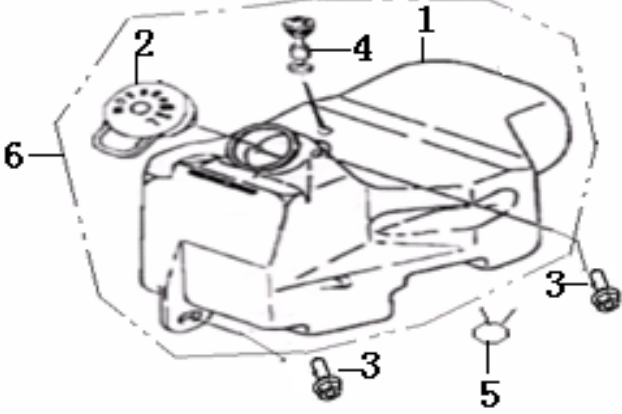

SPEEDOMETER ASSY.

NO.	CODE		QTY.
1	70000B920028	SPEEDOMETER COMP.	1
2	B05074001205	TAPPING SCREW 4X12MM	2
3	72900B920000	SPEEDOMETERCABLE COMP.	1
4	B24012920000	BULB 12V-3W	3
5	B24020221100	BULB 12V-2W	3
6	88900B92000X	KEY NUT (LEFT)	1
7	70003B920004	SPEEDOMETER COVER	1
8	76000B920001	DIGITAL WATCH	1
9	88900B92001X	KEY NUT(RIGHT)	1
10	B05074001205	TAPPING SCREW 4X12 MM	1

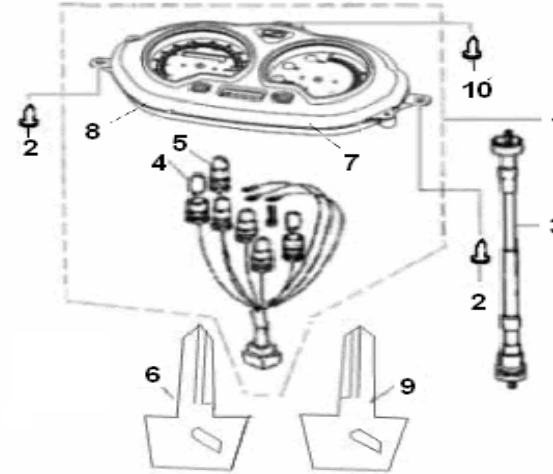

FLASHER LIGHT/HEAD

NO.	CODE		QTY.
1	81100B910002	FRONT LH INDICATOR	1
2	81300B910002	FRONT RH INDICATOR	1
3	08005X010000	SCREW W/WASHER 5X11.5MM	2
4	80000T090000	HEAD LIGHT ASSY. (E MARK)	1
4	80000T090001	HEAD LAMP ASSY.	1
5	B24012120000	BULB, 12V/10W	2
6	B24012920000	BULB 12V-3W	2
7	B24010520000	BULB (12V35/35W)	2
8	81302B910001	LIGHT COVER, FRONT R.	1
9	81102B910001	LIGHT COVER,FRONT L.	1
10	08011B030000	SCREW 3X28MM	2
11	B05075016005	TAPPING SCREW 5X16MM	2
12	B05074816005	TAPPING SCREW 5X16MM	2

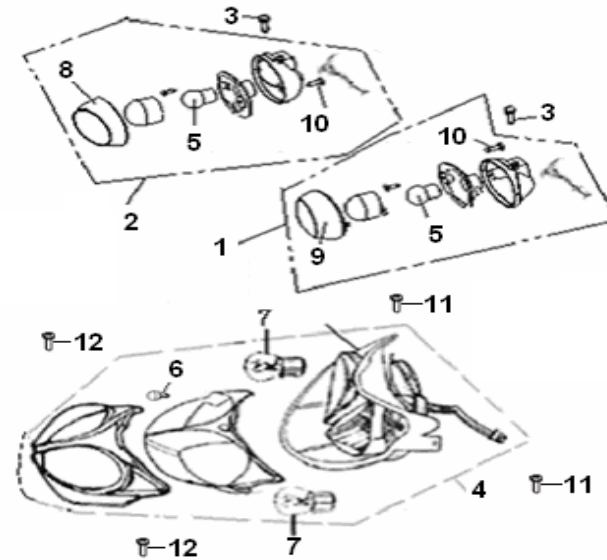

TAIL LIGHT

NO.	CODE		QTY.
1	81700B910002	REAR RH INDICATOR	1
2	81500B910002	REAR LH INDICATOR	1
3	81511B910000	FLASHER LIGHT CUSHION , L	1
4	B07030001005	WASHER 10MM	2
5	B04061012555	NUT 10X1.25MM	2
6	81708B910000	FLASHER LIGHT CUSHION , R	1
7	65802B910000	SPRING NUT 5MM	2
8	B04070600065	NUT 6MM	3
9	B24012120000	BULB, 12V/10W	2
10	08202B910000	LICENSE BRACKET	1
11	82008B910001	INDICATOR LENS	1
12	82000B910002	TAIL LAMP 12V/P21/5W	1
13	08009B910000	SCREW 4X28MM	2
14	82011G130000	RUBBER WASHER	3
15	B24013820000	BULB 12V 21/5W	1
16	81502B910001	LIGHT COVER, REAR L.	1
17	81702B910001	LIGHT COVER, REAR R.	1
18	08011B030000	SCREW 3X28MM	2
19	86502B910001	REAR REFLECTOR BELOW TAIL LAMP	1

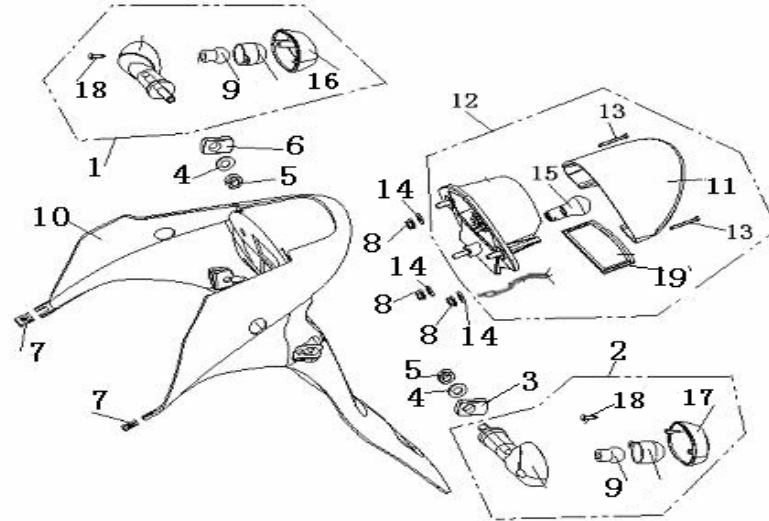

ELECTRICAL

NO.	CODE		QTY.
1	97701B910001	C.D.I. UNIT COMP.	1
2	96007B910000	CUSHION. C.D.I	1
3	96200B310000	IGNITION COIL ASSY	1
4	B02000502025	SCREW 5×20MM	1
5	96100B910000	BATTERY ASSY. 12V,4AH	1
6	92000B92000C	WIRE HARNESS ASSY.	1
7	96900B920000	WIRE HARNESS	1
8	96810B310000	FUSE 8A,250V	1
9	94100B920000	STARTER RELAY COMP.	1
10	96001K010000	BAND 8×250	3
11	96600B310000	RESISTOR COMP.	1
12	B01090601265	BOLT 6×12MM	2
13	96003K010000	BAND 8×200	3
14	96002K010000	BAND 8×150	1
15	B04000600055	NUT 6MM	1
16	B07000000605	SPRING WASHER 6MM	2
17	B07030000605	WASHER 6MM	2
18	B07000000505	SPRING WASHER 5MM	1
19	B07030000505	WASHER 5MM	1
20	96800B310000	FUSE COMP	1

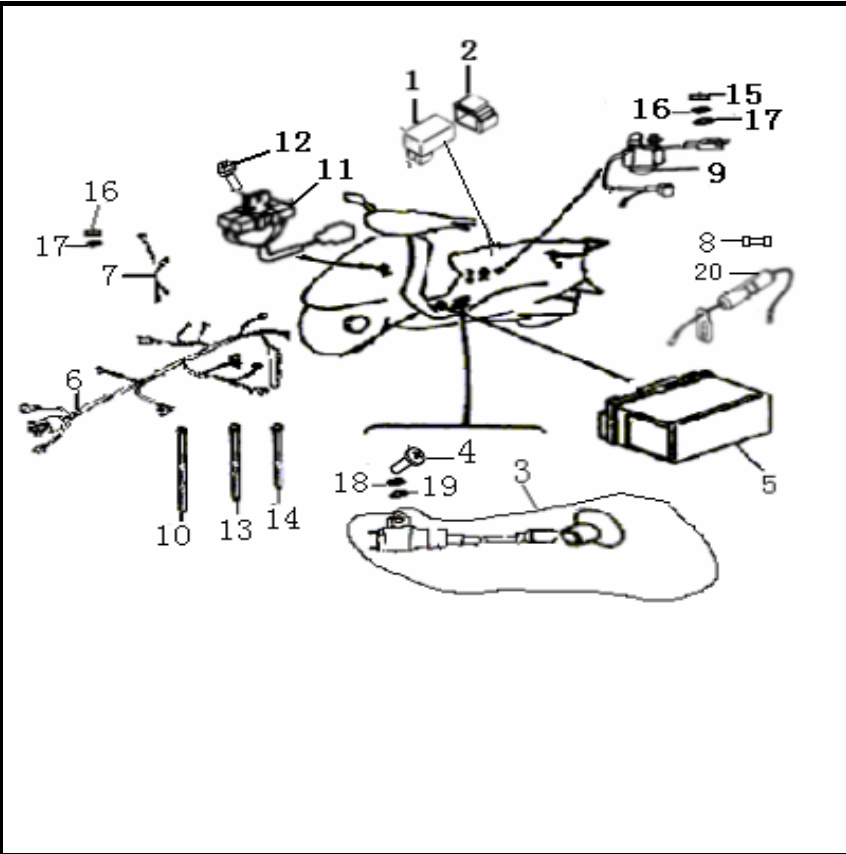

ELECTRICAL

NO.	CODE		QTY.
1	98801T020000	REGULATOR COMP.	1
2	B01090601265	BOLT 6×12MM	4
3	88100B920000	MAIN SWITCH ASSY.	1
4	B01090601265	BOLT 6×12MM	2
5	88000B920000	LOCK ASSY.	1
6	95100B340000	HORN (E MARK)	1
7	88800B920000	LOCK ASSY., SEAT	1
8	96500B91000B	FLASH&AUDIO PILOT COMP.	1
9	88500B920000	LOCK, COVER	1
10	88400B920000	LOCK ASSY., FUEL TANK	1
11	B07030000505	WASHER 5MM	2
12	B05074001005	TAPPING SCREW 4×10MM	2
13	88101B920000	COVER MAIN SWITCH	1
14	95701T180000	BAKT ALARMSYSTEM	1
15	95730B920002	ALARM SYSTEM HORN	1
16	95700B920002	ALARM ASSY.	1
17	B05074801305	TAPPING SCREW 4.8×13MM	1

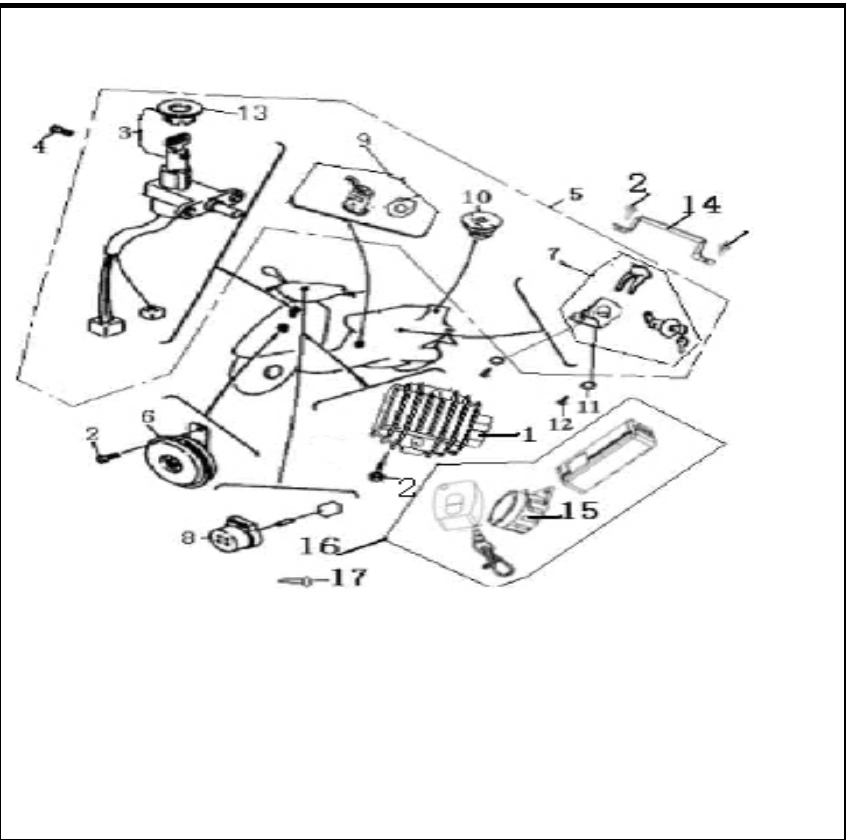

TOOL KIT

NO.	CODE		QTY.
1	02110B910000	TOOL BAG	1
2	02102B910000	SPARK PLUG SOCKET	1
3	02101B910000	SPARK PLUG SOCKET HANDLE	1
4	02103B910000	SCREW DRIVER	1
5	02104B910000	HANDLE	1
6	02114B910000	FILTER, OIL TANK	1
7	02115B910000	RR. ABSORBER ADJUSTER	1
8	02117B920000	WRENCH 35	1

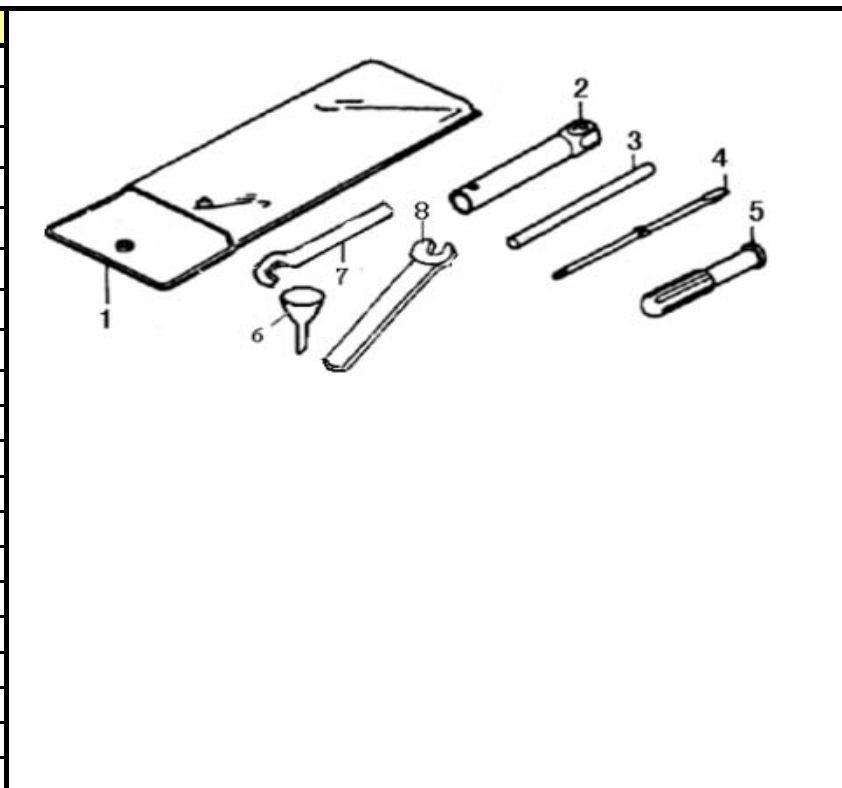

STICKER

NO.	CODE		QTY.
1	05531B920000	EPA STICKER	1
2	05567BMBT002	COUNTRY OF ORIGIN	1
3	B100432007P0	RIVET3.2×7MM	2
4	57001B920000	FRAME BODY NO. PLATE	1

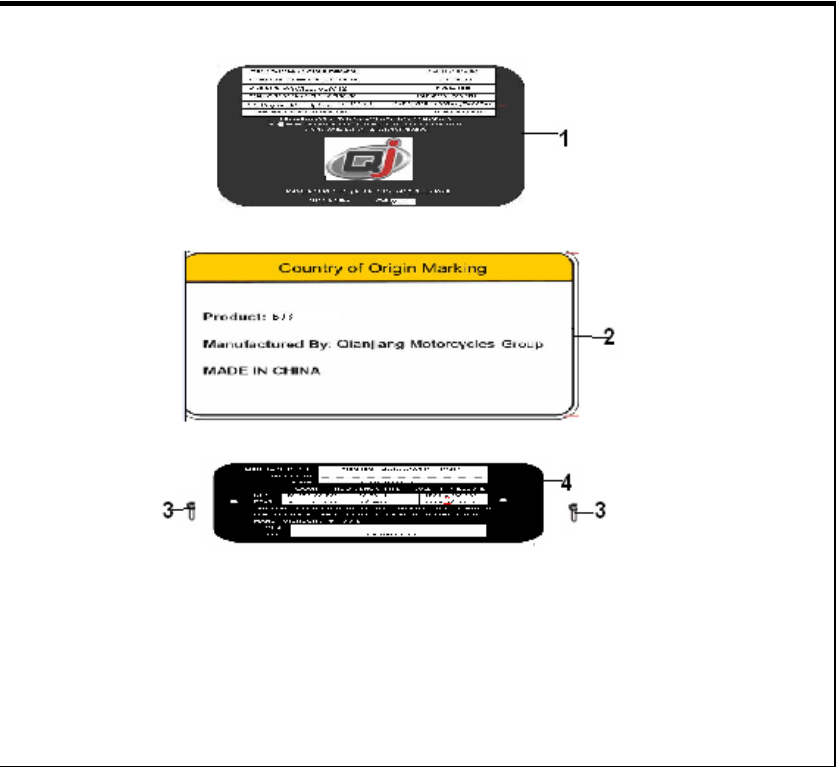

ENGINE ATTACHMENT

NO.	CODE		QTY.
1	08351B91C100	STARTING SHAFT (SILVER)	1
2	B02050602565	SCREW 6×25MM	1

